

MAIN DIMENSIONS

REVISION	Muutos	Pvm	AUTHOR
M		7.11.2016	jaripe+
N		30.11.2016	ismok
O		16.1.2019	villes+

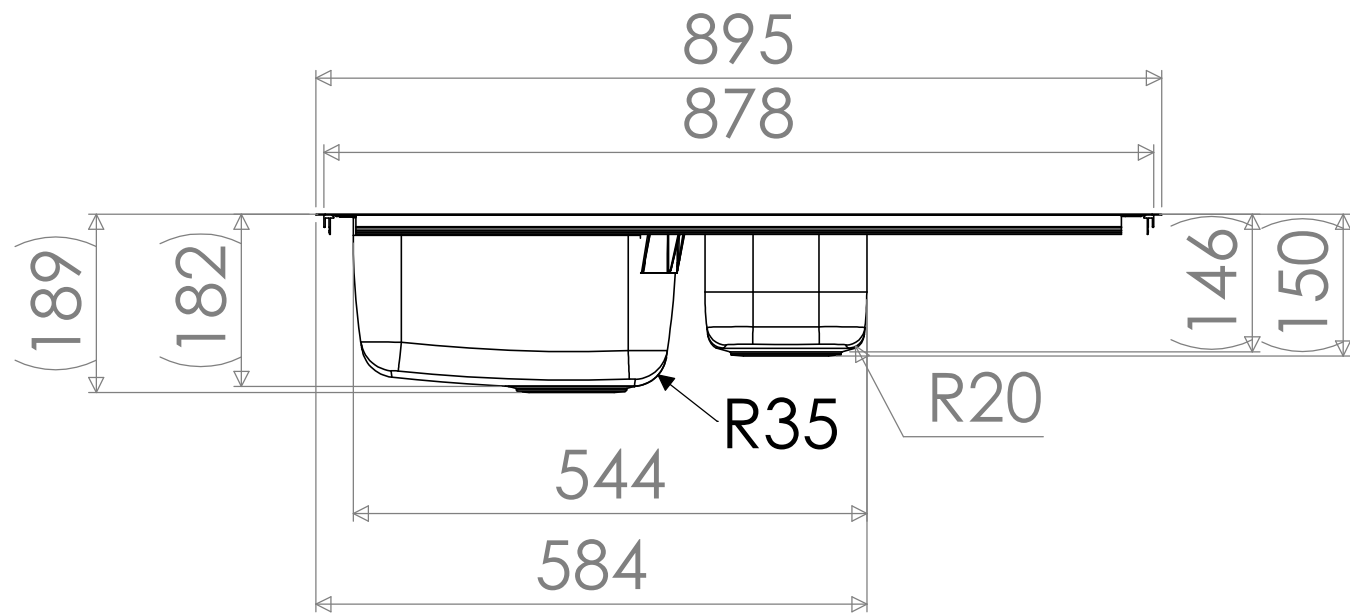

A (2:1)

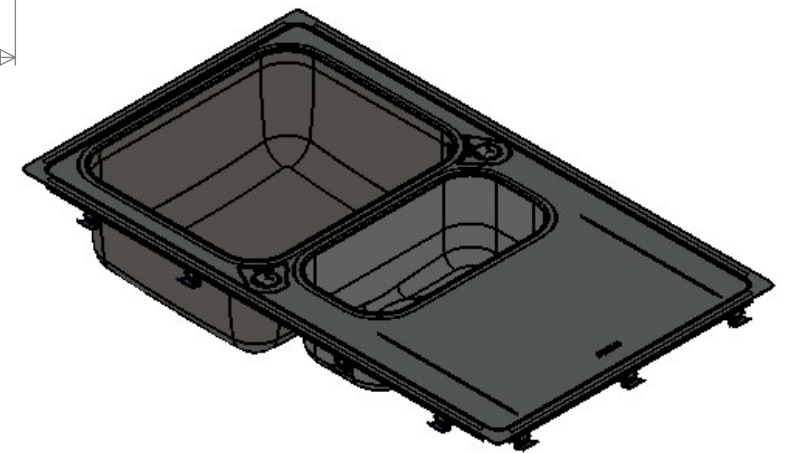
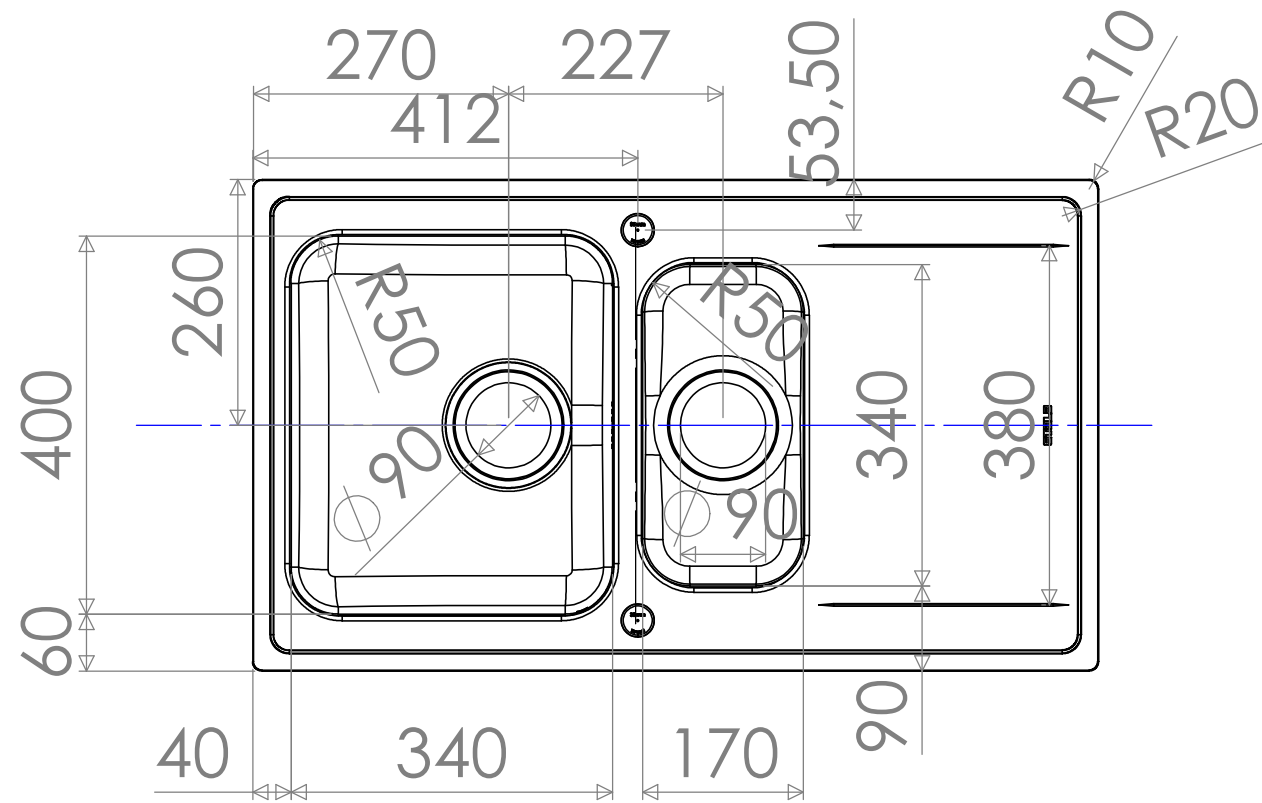
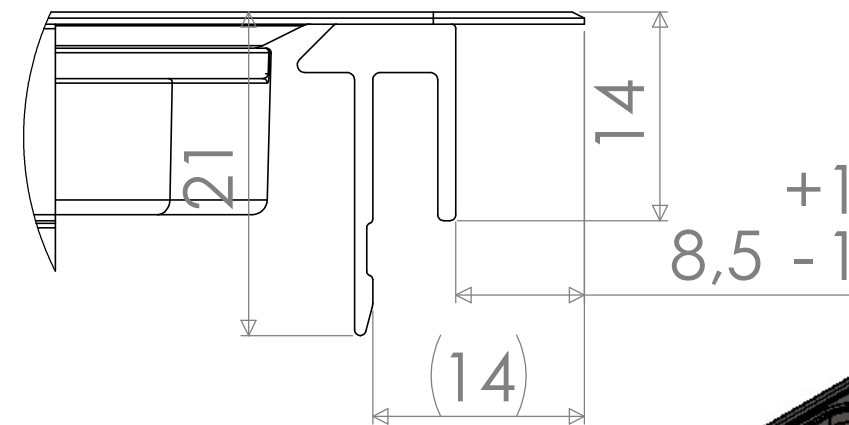
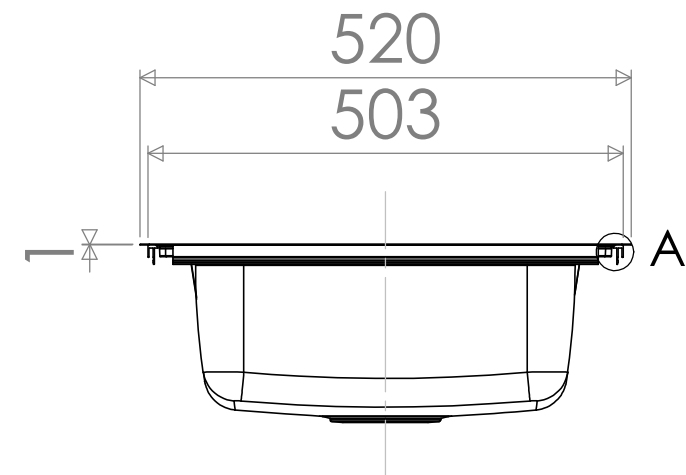

	Massa 32.75 kg	Yleistoleranssi ISO-2768-m	Suunnittelija JP	Pvm 18.6.2007
	Mittakaava A3 1:8		Nimike EASE	Tarkastaja
 www.stala.com	Nimitys MF-40-17S		Piirustusnumero 10101	Sivu 1/6
	Technical Data Sheet			Rev O

WORKTOP ASSEMBLY VIEW

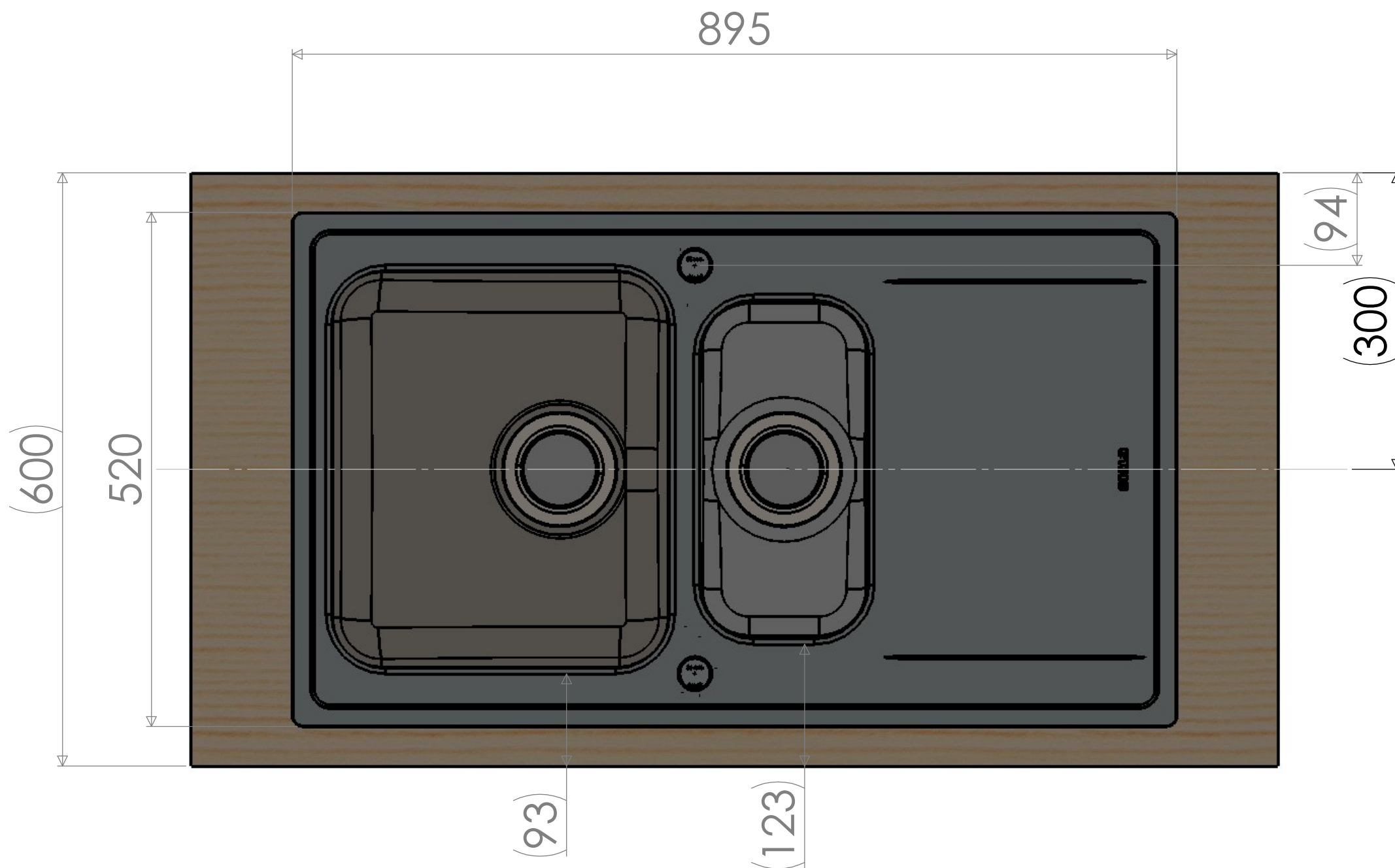

	Massa	32.75 kg	Yleistoleranssi	ISO-2768-m	Suunnittelija	JP	Pvm	18.6.2007
	Mittakaava	A3 1:5	Nimike	EASE	Tarkastaja		Pvm	
 www.stala.com	Nimitys		MF-40-17S	Piirustusnumero		10101	Sivu	2/6
	Technical Data Sheet						Rev	O

SPACE REQUIREMENTS

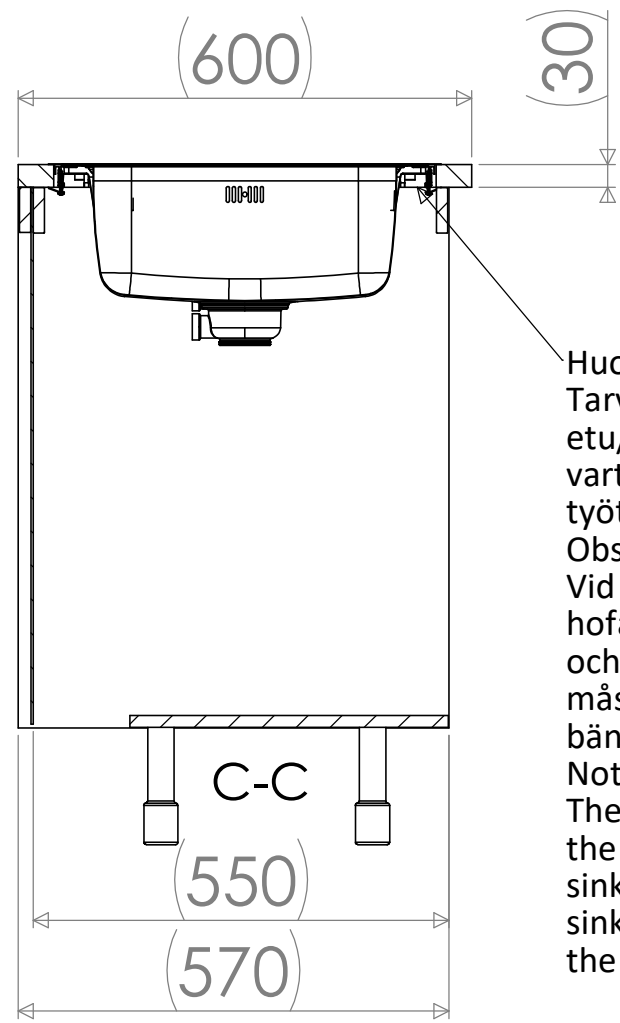
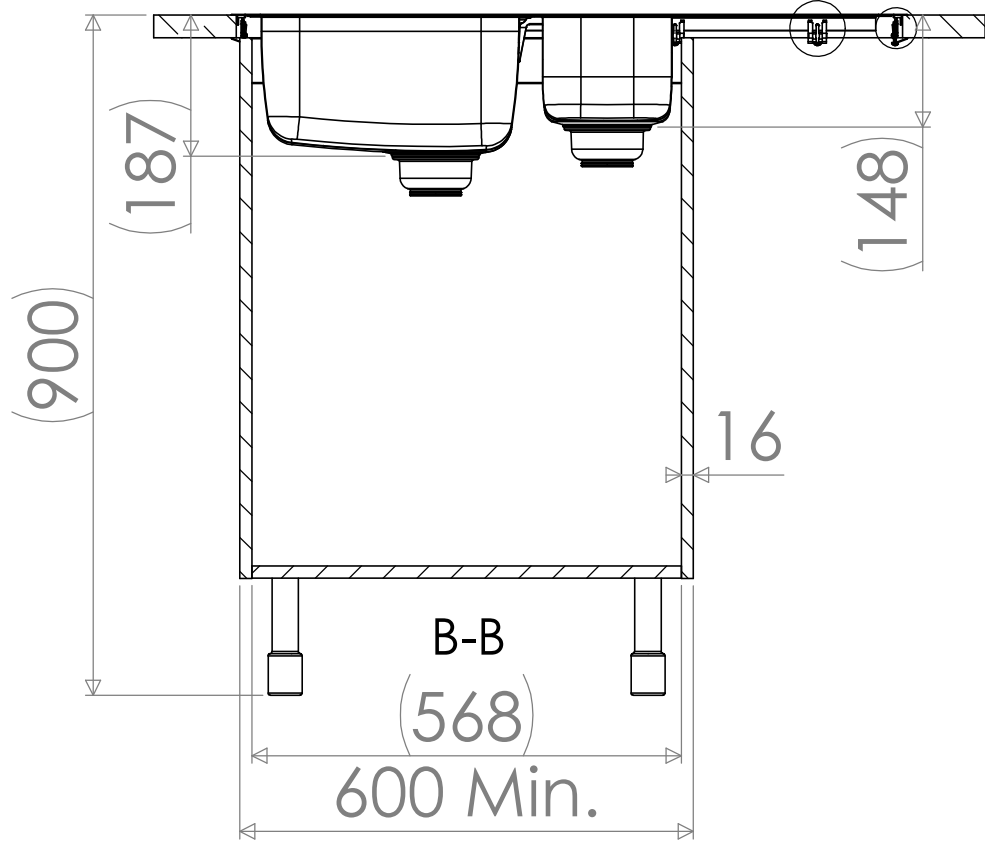

D (1 : 1)

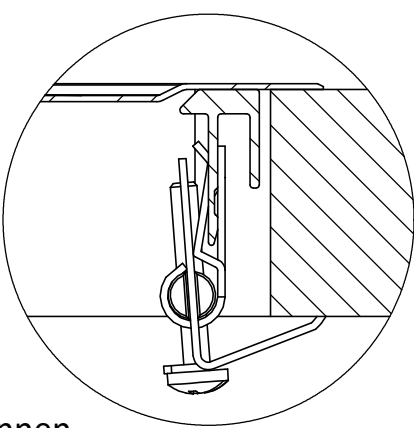

Huom!
 Tarvittaessa kaapin väliseinää ja etu/takalistaa lovetettava kiinnikkeitä varten ja pesuallas on kiinnitettävä ennen työtason asennusta.

Obs!
 Vid behov måste en inskärning för hofästena göras i skåpets mellanvägg och förbindningslist och diskbänken måste fästas innan du monterar bänkskivan.

Notice!
 The partition walls and front/back list of the cupboard must be notched for the sink mountings when needed and the sink must be fastened before installing the worktop.

E (1 : 1)

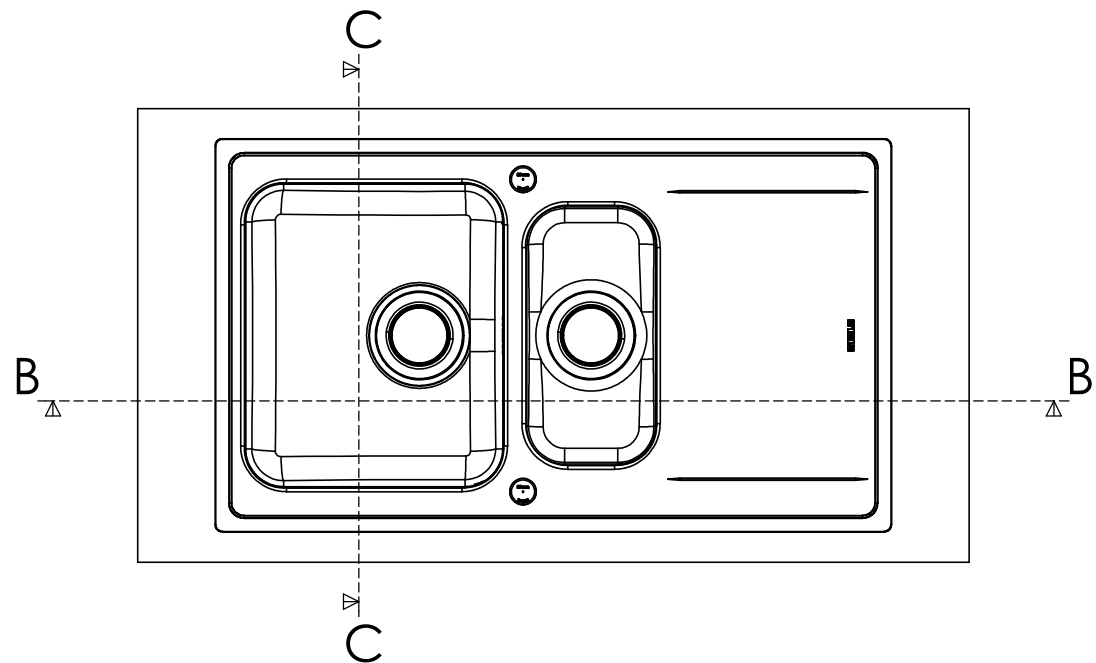
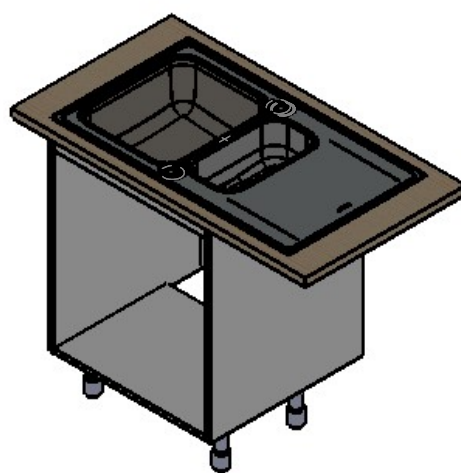
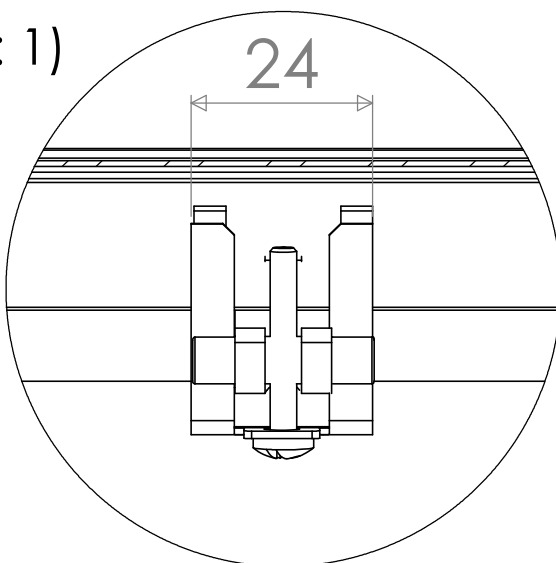

	Massa 32.75 kg	Yleistoleranssi ISO-2768-m	Suunnittelija JP	Pvm 18.6.2007
	Mittakaava A3 1:10	Nimike EASE	Tarkastaja	Pvm
 www.stala.com	Nimitys MF-40-17S	Piirustusnumero 10101	Sivu 3/6	Rev O
	Technical Data Sheet			

CUT - OUT FOR BUILD ON

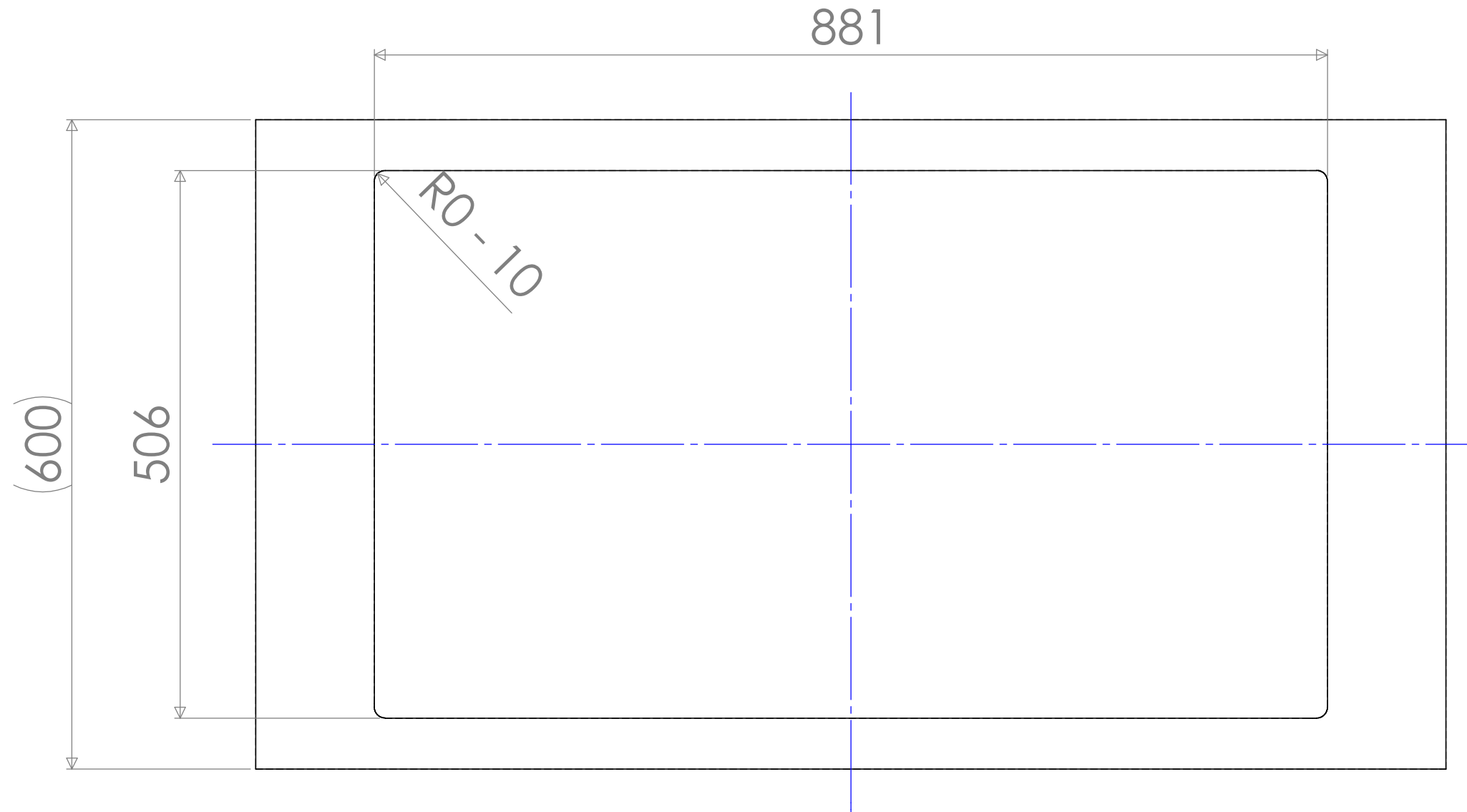

	Massa	32.75 kg	Yleistoleranssi	ISO-2768-m	Suunnittelija	JP	Pvm	18.6.2007
	Mittakaava	A3 1:5	Nimike	EASE	Tarkastaja		Pvm	
	Nimitys	MF-40-17S	Piirustusnumero	10101	Sivu	4/6	Rev	O
		Technical Data Sheet						

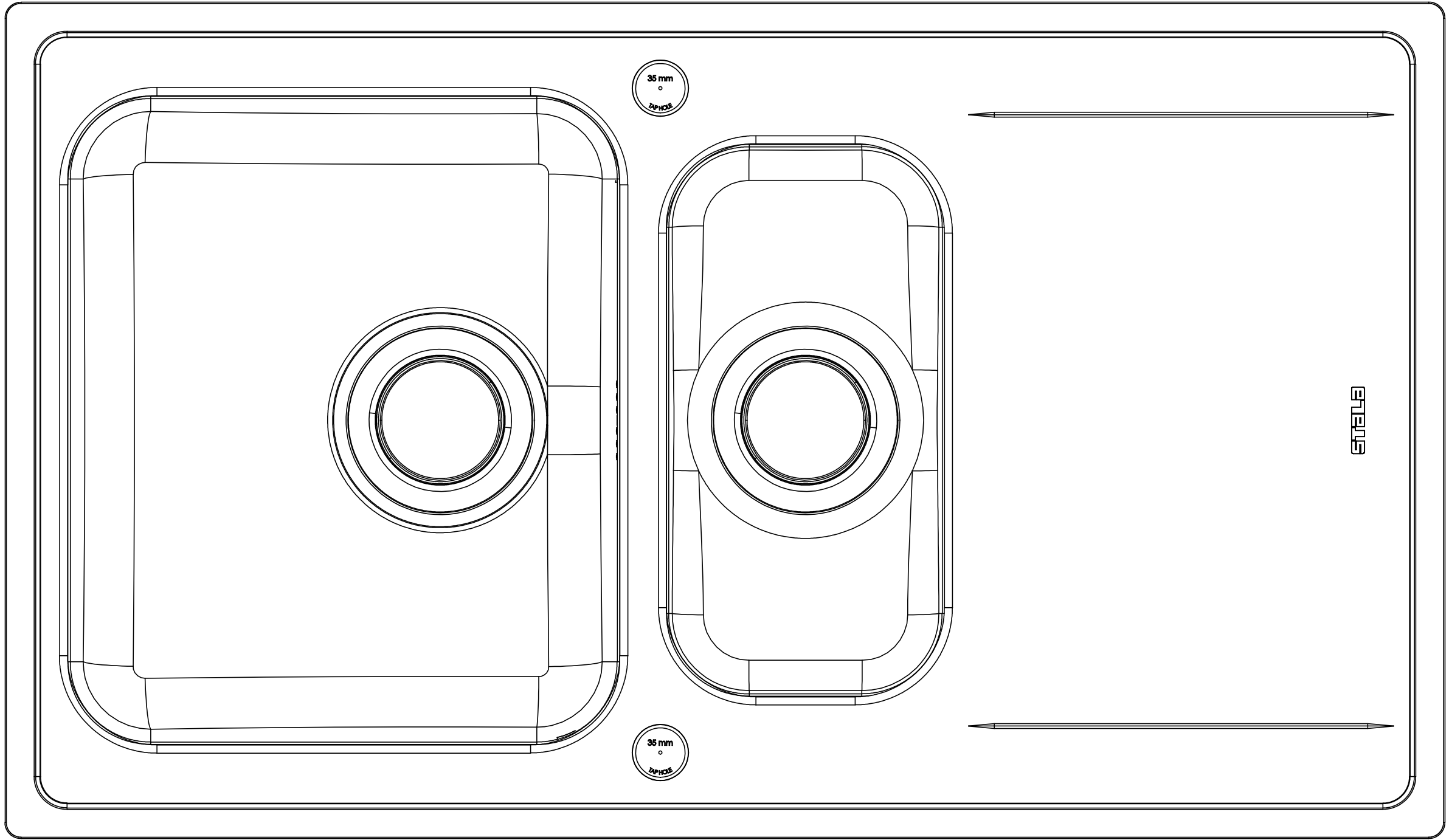

STELLA

