

MAIN DIMENSIONS

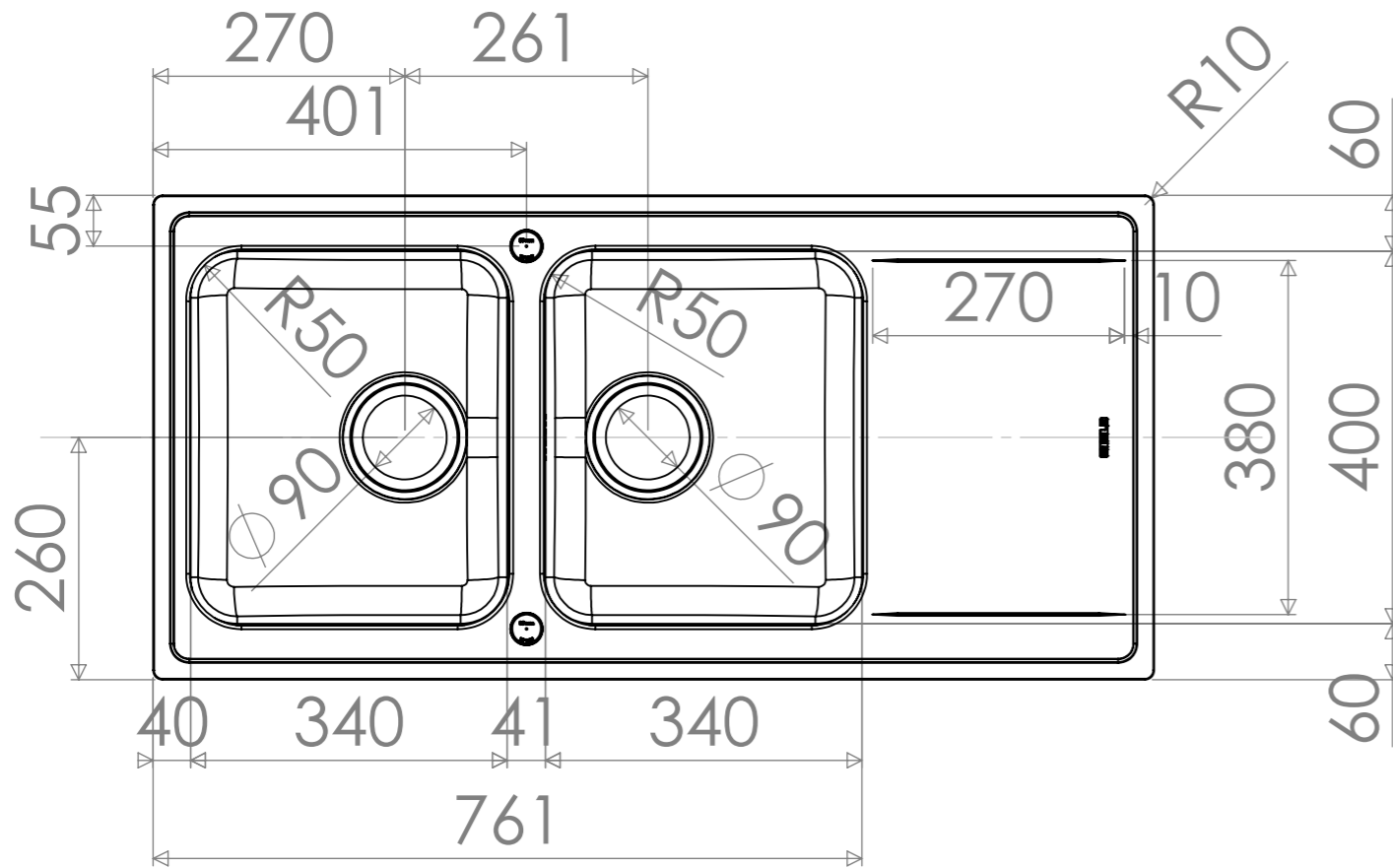

REVISION	Muutos	Pvm	AUTHOR
M		25.2.2016	ismok
N		7.11.2016	jaripe+
O		16.1.2019	villes+

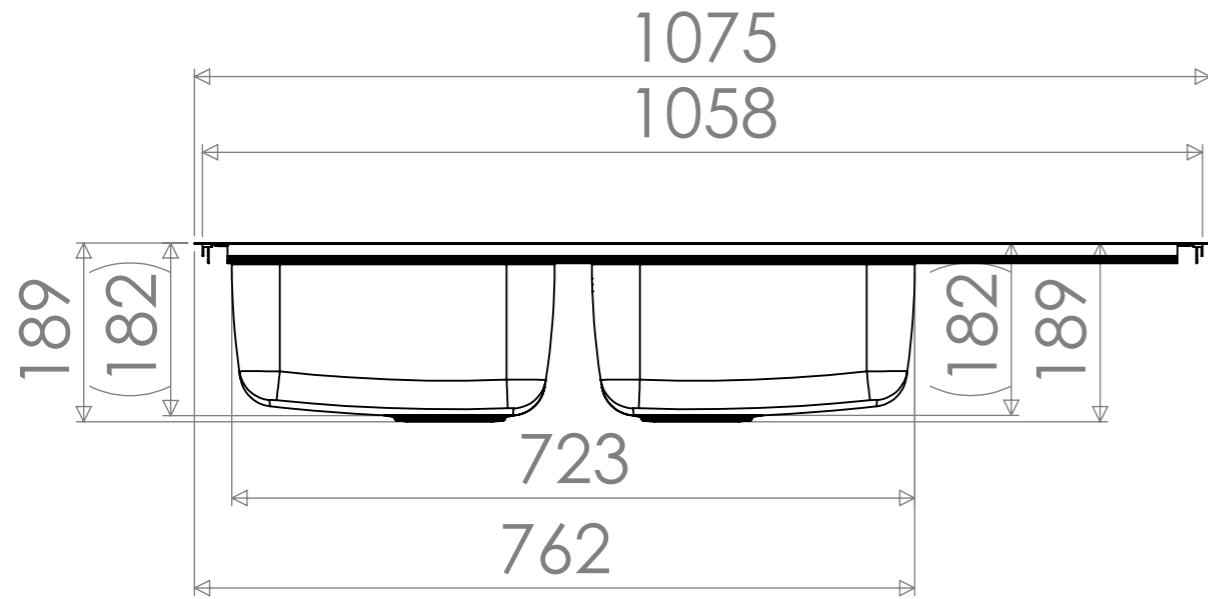
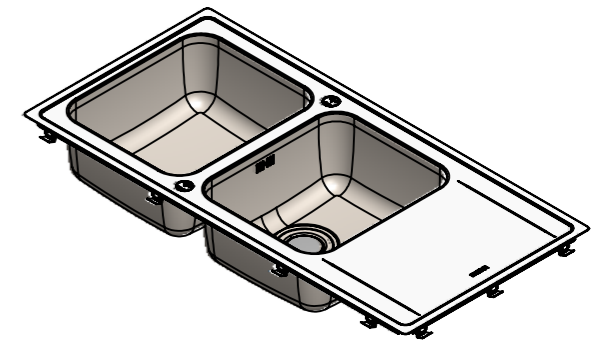
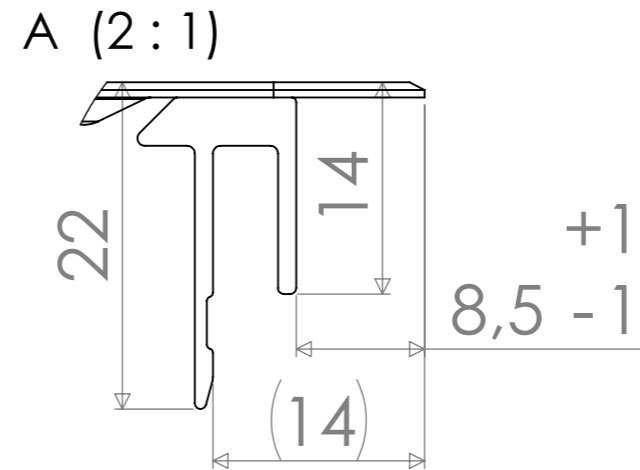
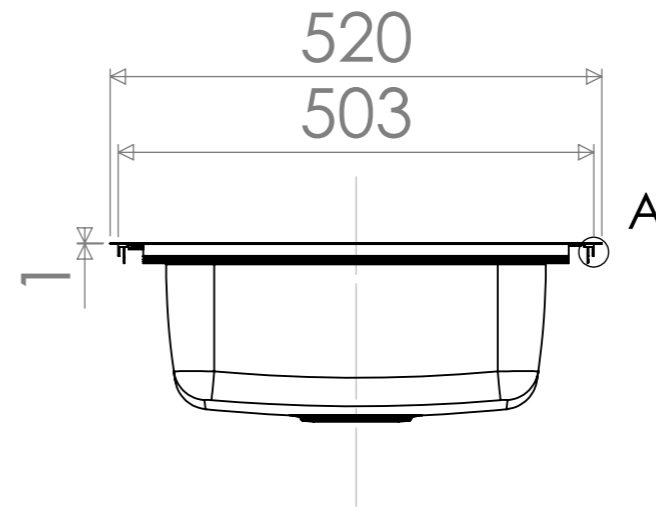

Scale 1:10

	Massa <b>32.58 kg</b>	Yleistoleranssi <b>ISO-2768-m</b>	Suunnittelija <b>JP</b>	Pvm <b>18.6.2007</b>
	Mittakaava <b>A3 1:8</b>	Nimike <b>EASE</b>	Tarkastaja	Pvm
 www.stala.com	Nimitys <b>MA-40-40S</b> <b>Technical Data Sheet</b>		Piirustusnumero <b>10105</b>	Sivun <b>1/6</b>
				Rev <b>O</b>

WORKTOP ASSEMBLY

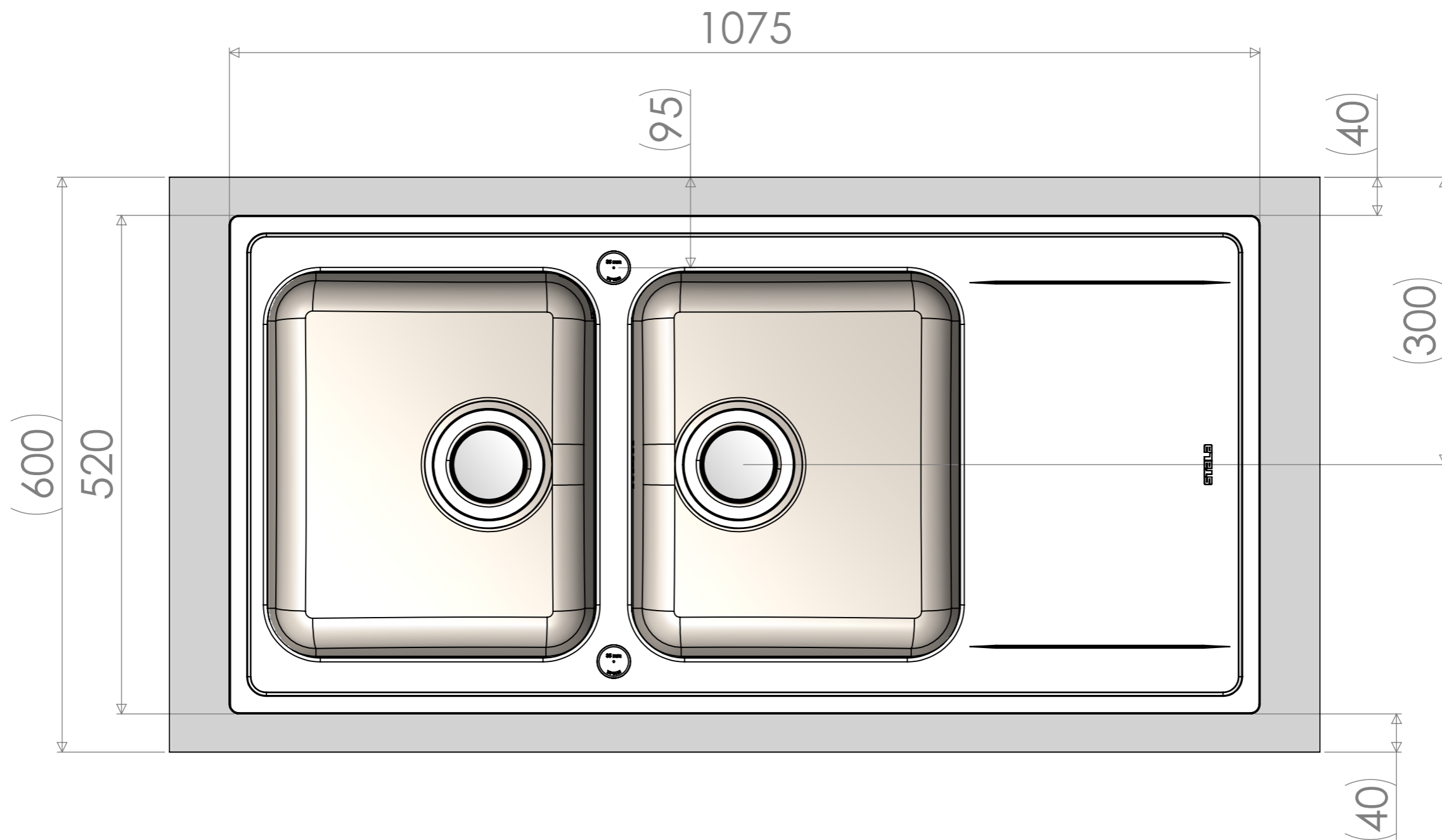

	Massa <b>32.58 kg</b>	Yleistoleranssi <b>ISO-2768-m</b>	Suunnittelija <b>JP</b>	Pvm <b>18.6.2007</b>
	Mittakaava <b>A3 1:5</b>	Nimike <b>EASE</b>	Tarkastaja	Pvm
 www.stala.com	Nimitys <b>MA-40-40S</b> <b>Technical Data Sheet</b>		Piirustusnumero <b>10105</b>	Sivun <b>2/6</b>
				Rev <b>O</b>

SPACE REQUIREMENTS

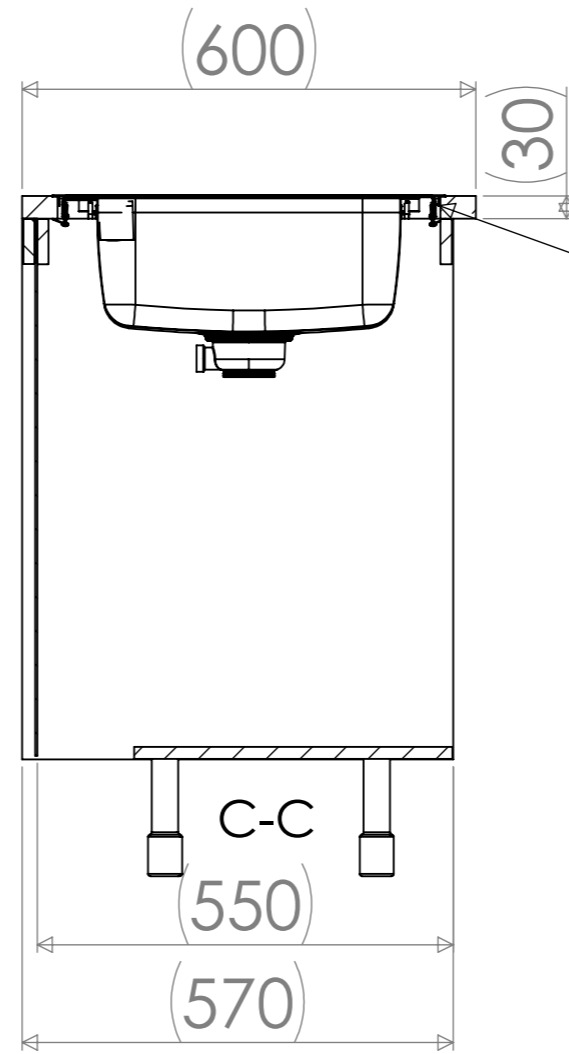
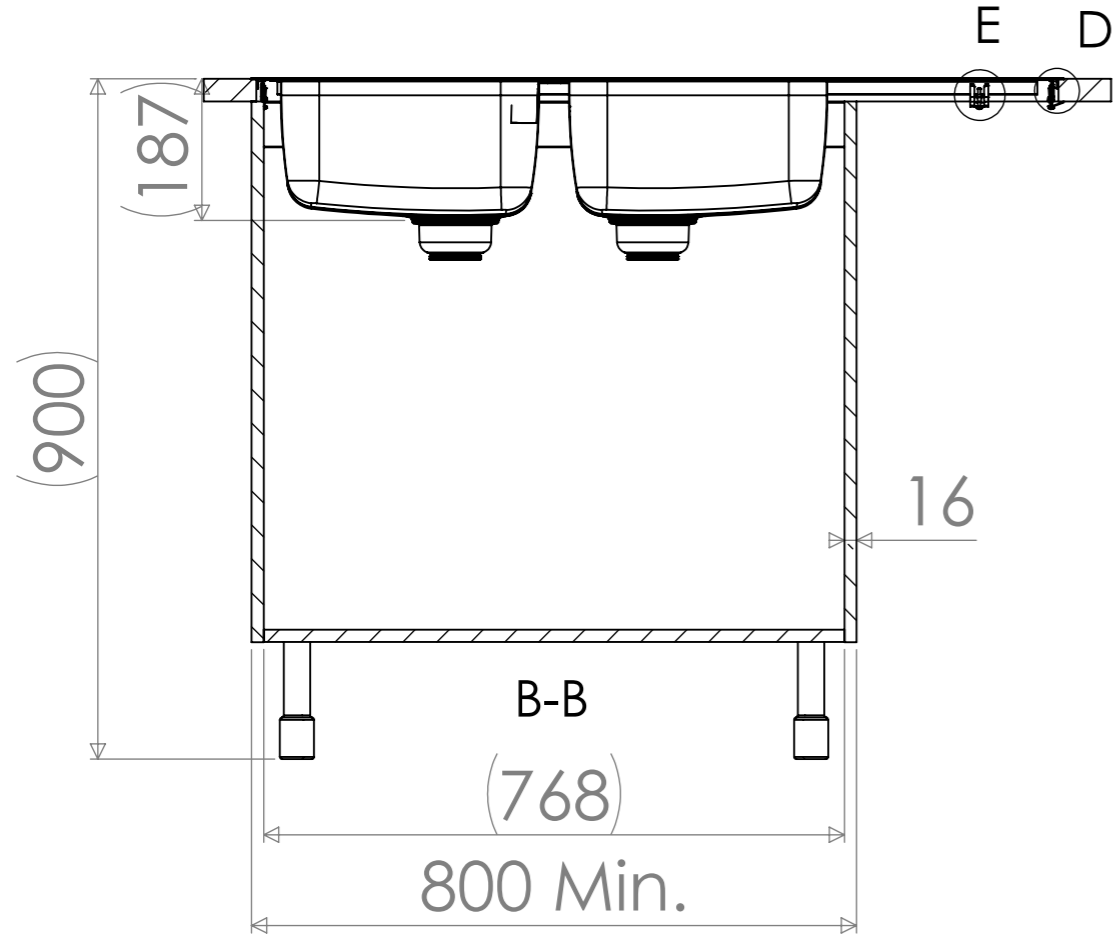

D (1 : 1)

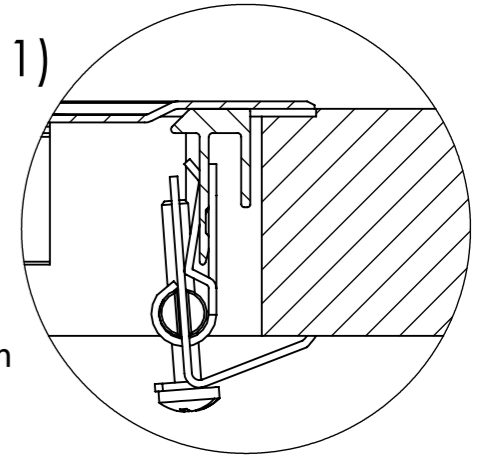

Huom!  
 Tarvittaessa kaapin väliseinää ja etu/takalistaa lovetettava kiinnikkeitä varten ja pesuallas on kiinnitettävä ennen työtason asennusta.  
 Obs!  
 Vid behov måste en inskärning för hofästena göras i skåpets mellanvägg och förbindningslist och diskbänken måste fästas innan du monterar bänkskivan.  
 Notice!  
 The partition walls and front/back list of the cupboard must be notched for the sink mountings when needed and the sink must be fastened before installing the worktop.

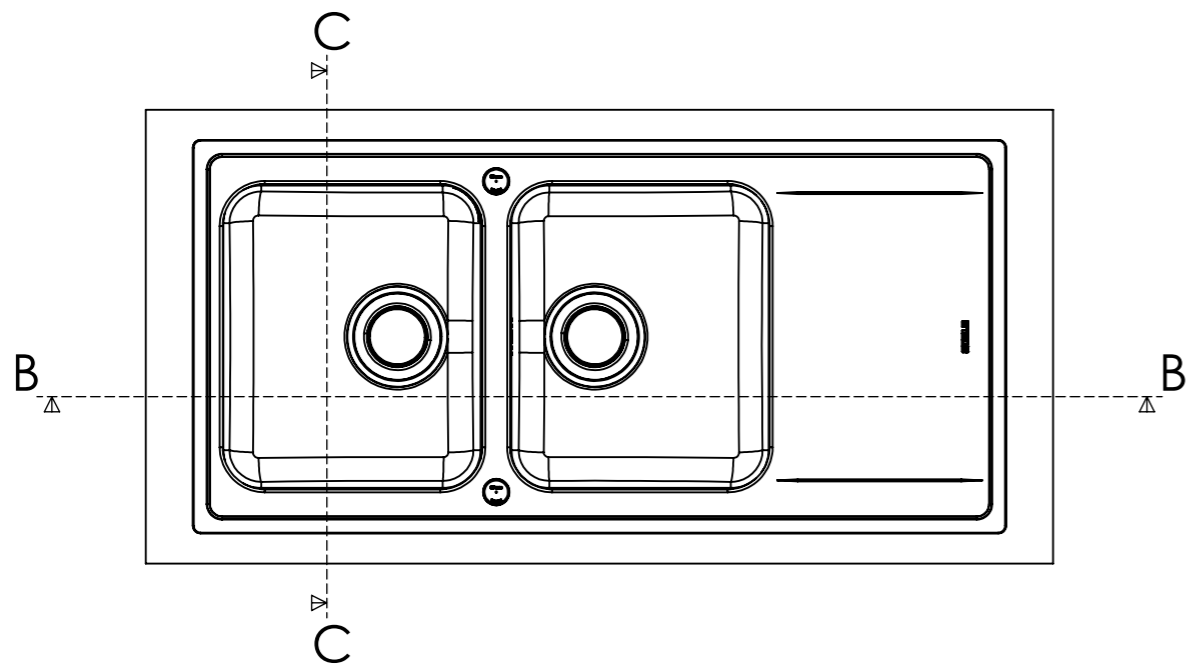

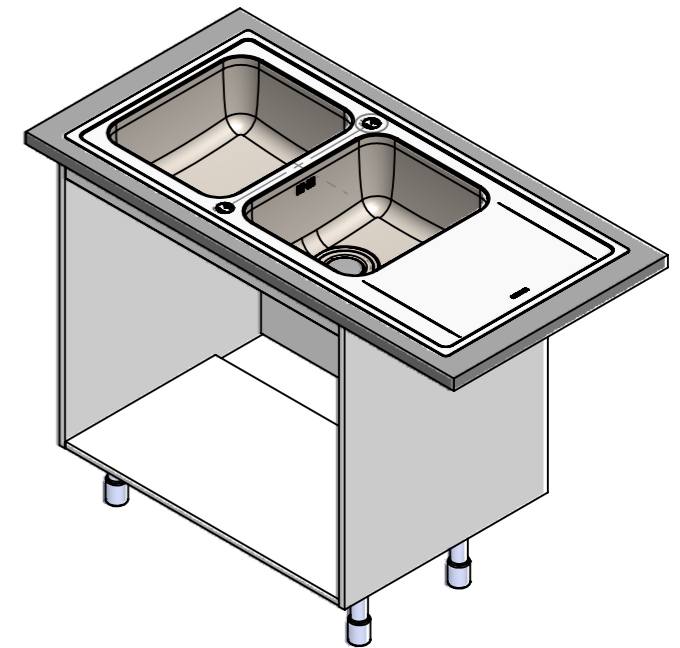
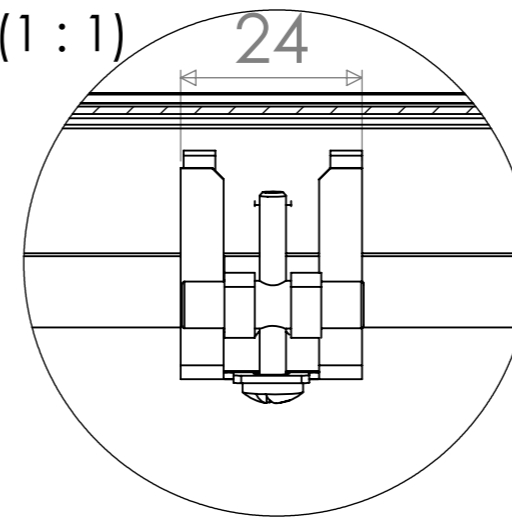

E (1 : 1)

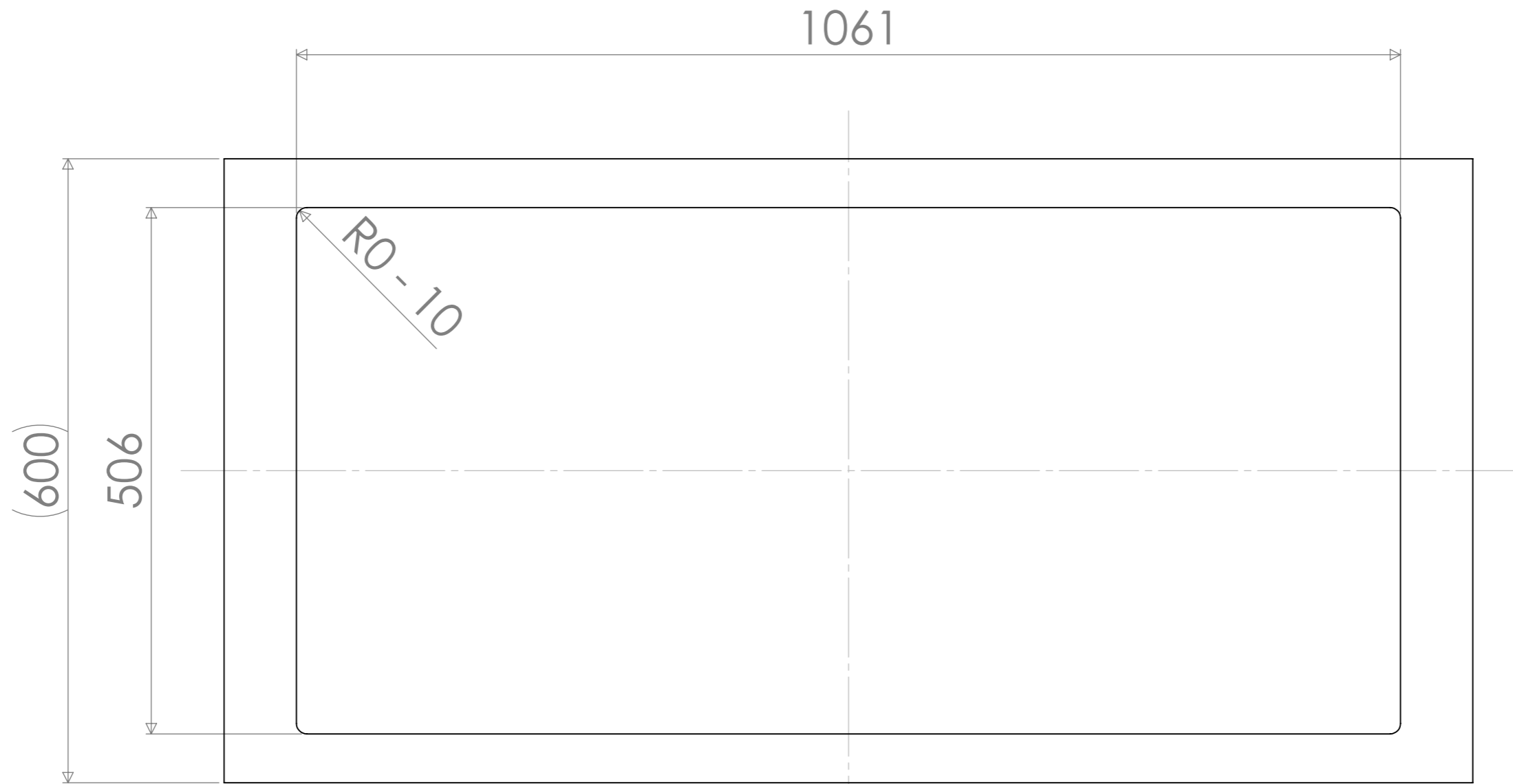

	Massa <b>32.58 kg</b>	Yleistoleranssi <b>ISO-2768-m</b>	Suunnittelija <b>JP</b>	Pvm <b>18.6.2007</b>
	Mittakaava <b>A3 1:10</b>	Nimike <b>EASE</b>	Tarkastaja	Pvm
 www.stala.com	Nimitys <b>MA-40-40S</b>	Piirustusnumero <b>10105</b>	Siv <b>3/6</b>	Rev <b>O</b>
	Technical Data Sheet	Pvm	Pvm	Pvm

CUT - OUT FOR BUILT ON



	Massa <b>32.58 kg</b>	Yleistoleranssi <b>ISO-2768-m</b>	Suunnittelija <b>JP</b>	Pvm <b>18.6.2007</b>
	Mittakaava <b>A3 1:5</b>	Nimike <b>EASE</b>	Tarkastaja	Pvm
 www.stala.com	Nimitys <b>MA-40-40S</b> <b>Technical Data Sheet</b>	Piirustusnumero <b>10105</b>	Sivun <b>4/6</b>	Rev <b>O</b>

