

# MAIN DIMENSIONS

REVISION	Muutos	Pvm	AUTHOR
K	TDS UPDATING	19.2.2016	ismok
M		25.2.2016	ismok

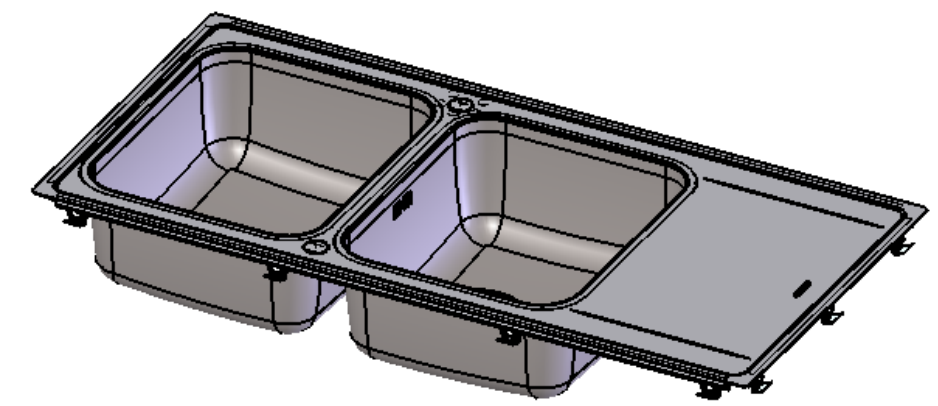
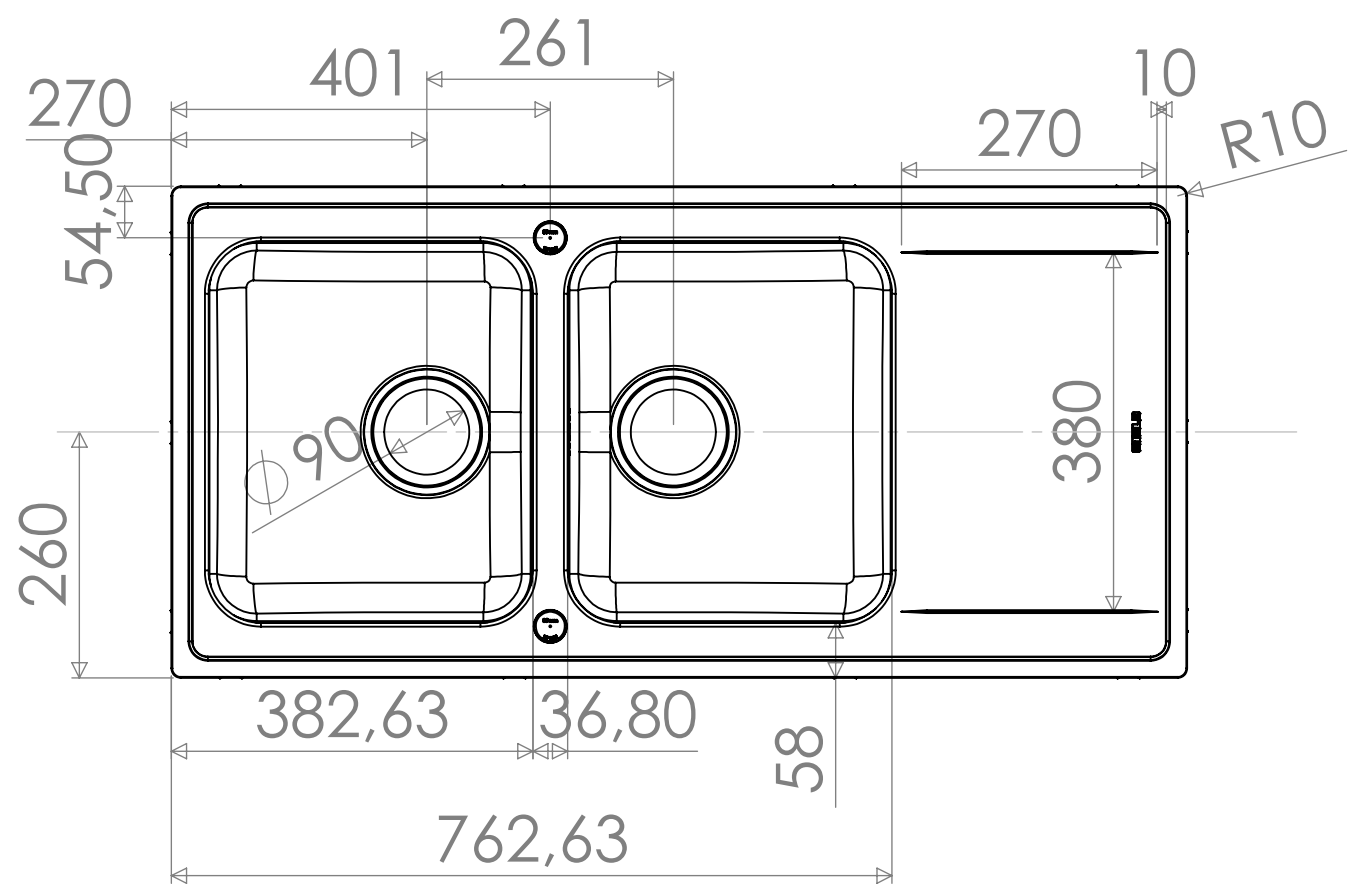
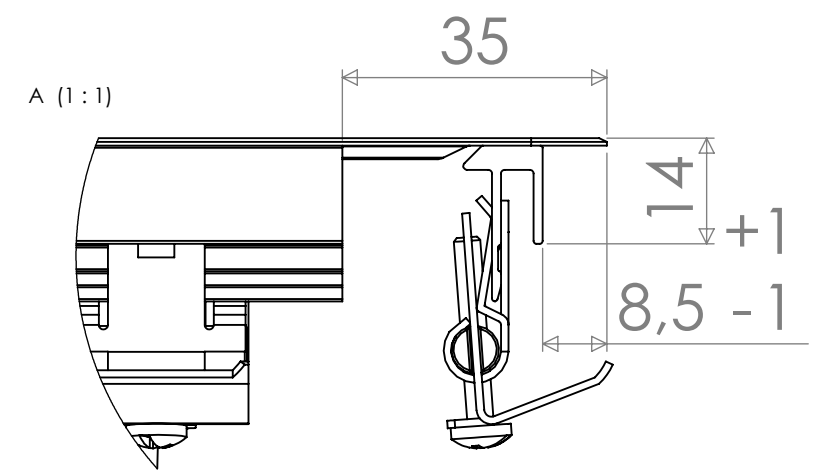
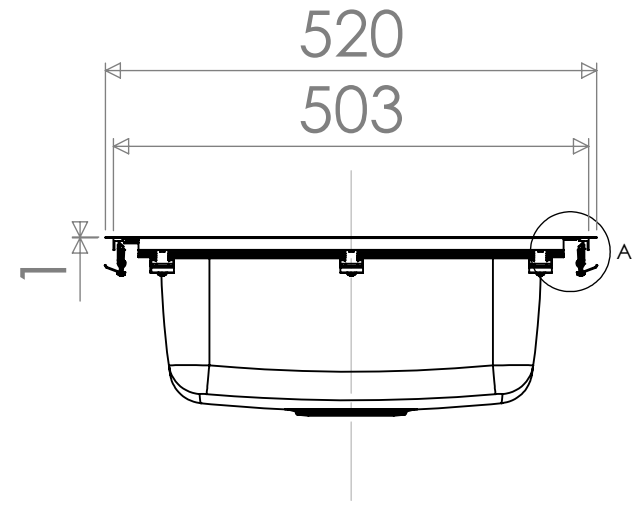
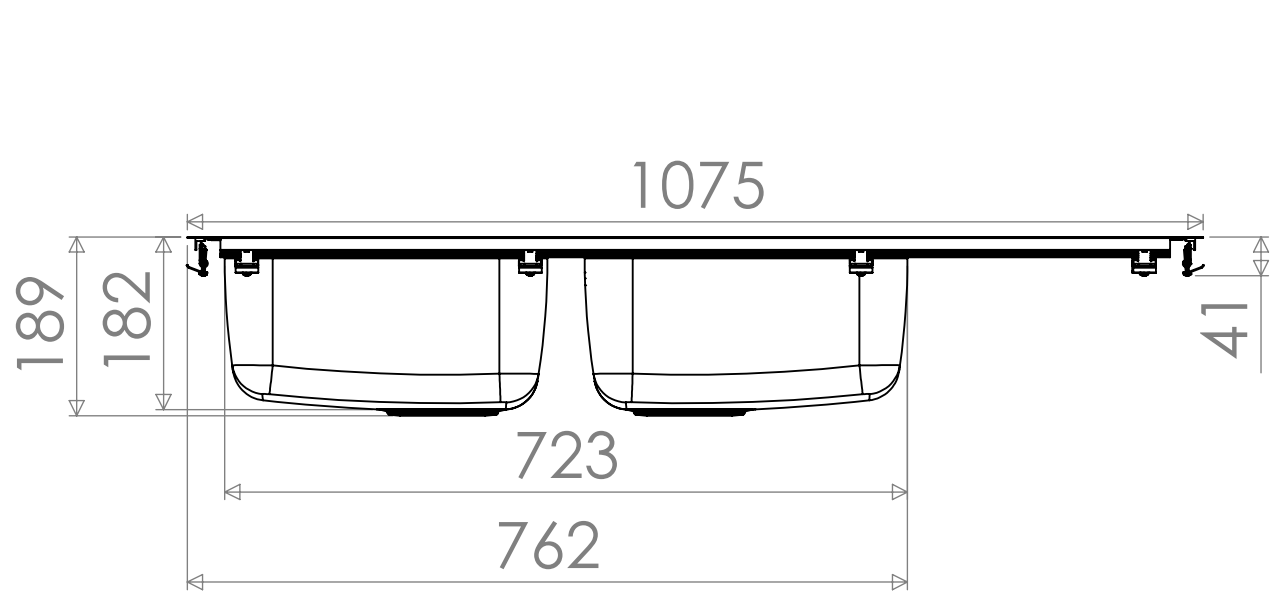

Scale 1:10

	Massa <b>15.10 kg</b>	Yleistoleranssi <b>ISO-2768-m</b>	Suunnittelija <b>JP</b>	Pvm <b>18.6.2007</b>
	Mittakaava <b>A3 1:8</b>	Nimike <b>EASE</b>	Tarkastaja	Pvm
 www.stala.com	Nimitys <b>MA-40-40S</b>	Piirustusnumero <b>10105</b>	Sivu <b>1/6</b>	Rev <b>M</b>
	Technical Data Sheet	<b>10105</b>		

# WORKTOP ASSEMBLY VIEW

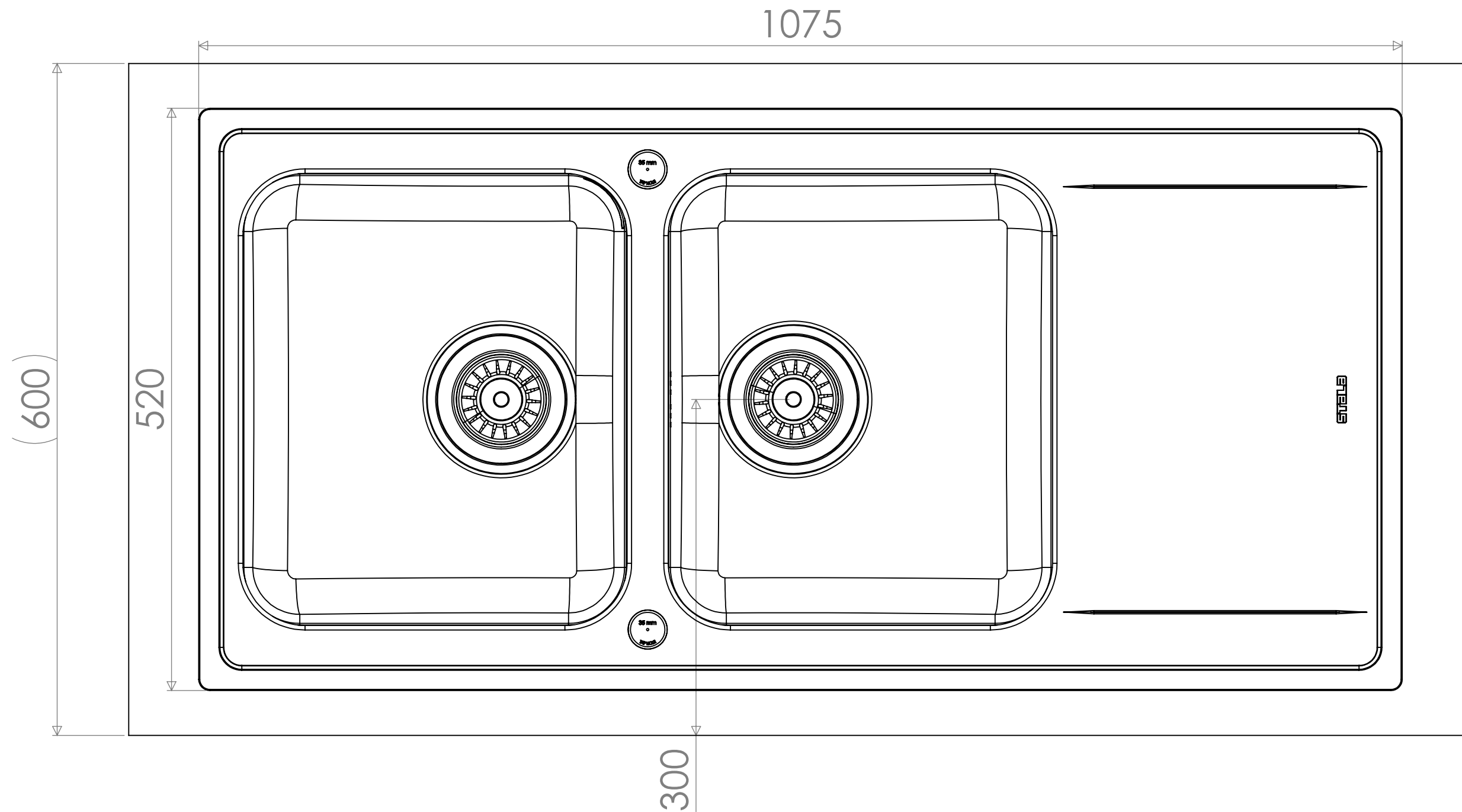

	Massa <b>15.10 kg</b>	Yleistoleranssi <b>ISO-2768-m</b>	Suunnittelija <b>JP</b>	Pvm <b>18.6.2007</b>
	Mittakaava <b>A3 1:4</b>	Nimike <b>EASE</b>	Tarkastaja	Pvm
 www.stala.com	Nimitys <b>MA-40-40S</b>	Piirustusnumero <b>10105</b>	Siv <b>2/6</b>	Rev <b>M</b>
	Technical Data Sheet			

# SPACE REQUIREMENTS

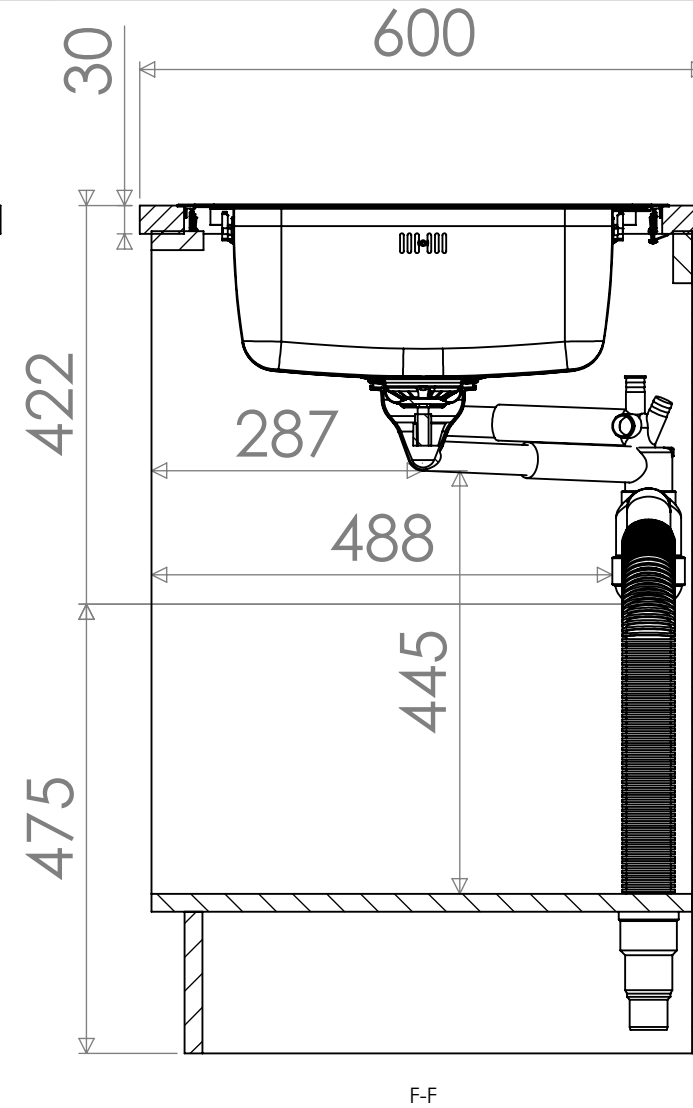
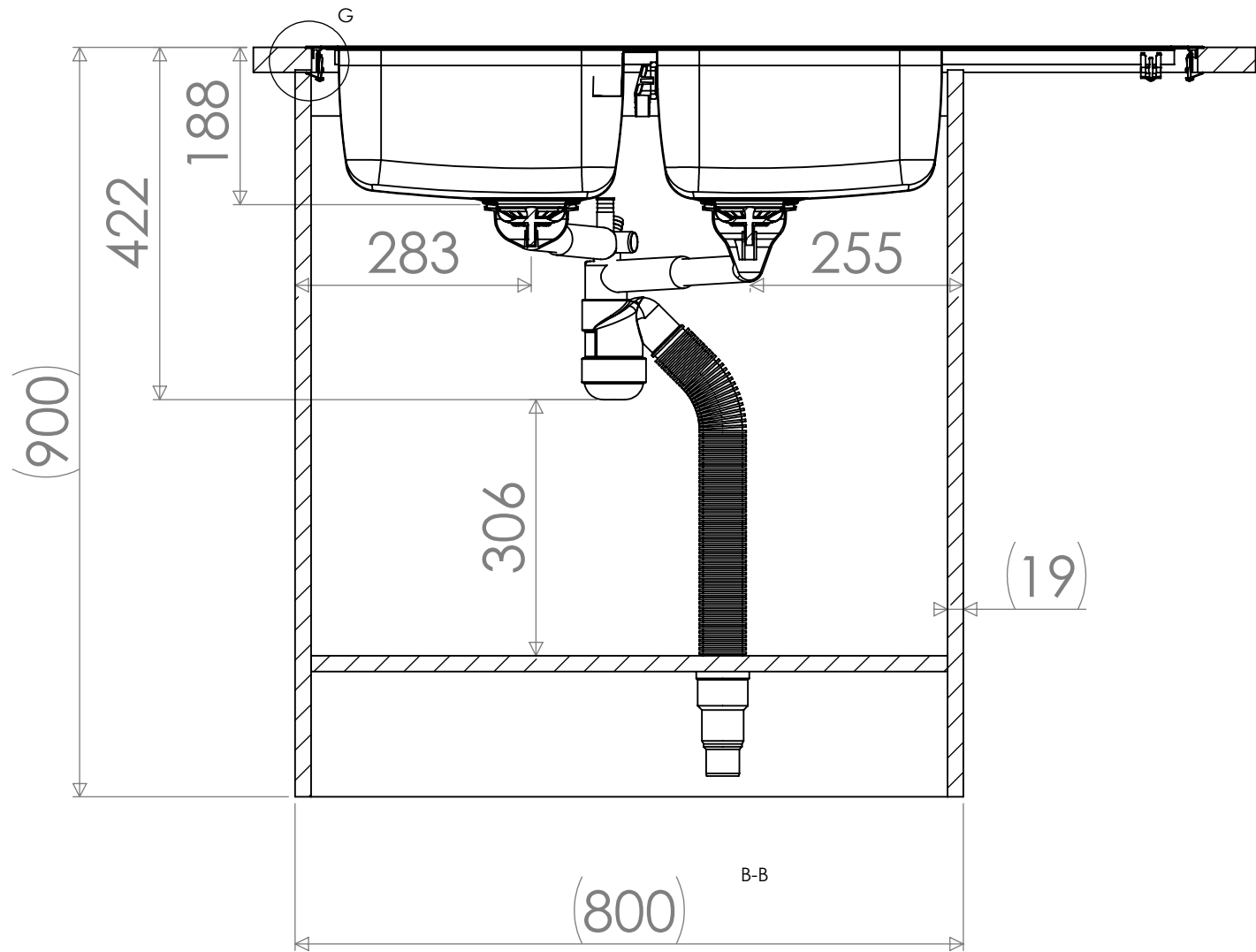

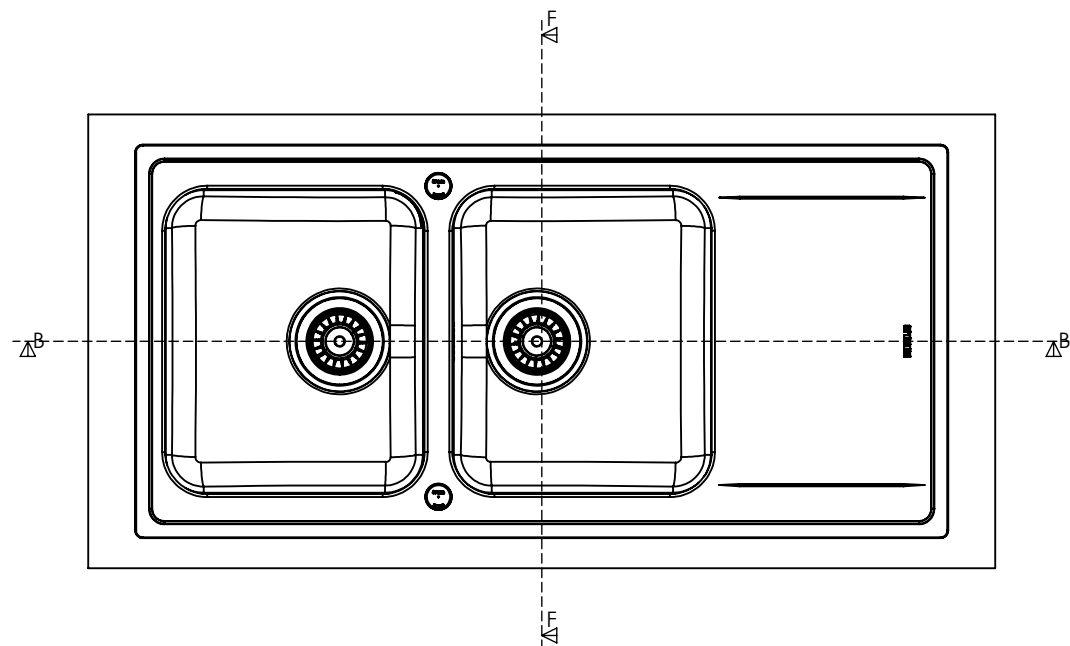

Huom! Obs! Notice!  
 Tarvittaessa kaapin väliseinää lovetettava kiinnikkeitä varten  
 Vid behov en inskärning för hofästena göras i skåpets mellanväg.  
 The partition walls of the cupboard must be notched for the sink mountings when needed.

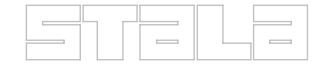

 www.stala.com	Massa <b>15.10 kg</b>	Yleistoleranssi <b>ISO-2768-m</b>	Suunnittelija <b>JP</b>	Pvm <b>18.6.2007</b>
	Mittakaava <b>A3 1:8</b>	Nimike <b>EASE</b>	Tarkastaja	Pvm
Nimitys <b>MA-40-40S</b>			Piirustusnumero <b>10105</b>	Sivun <b>3/6</b>
Technical Data Sheet			Rev <b>M</b>	

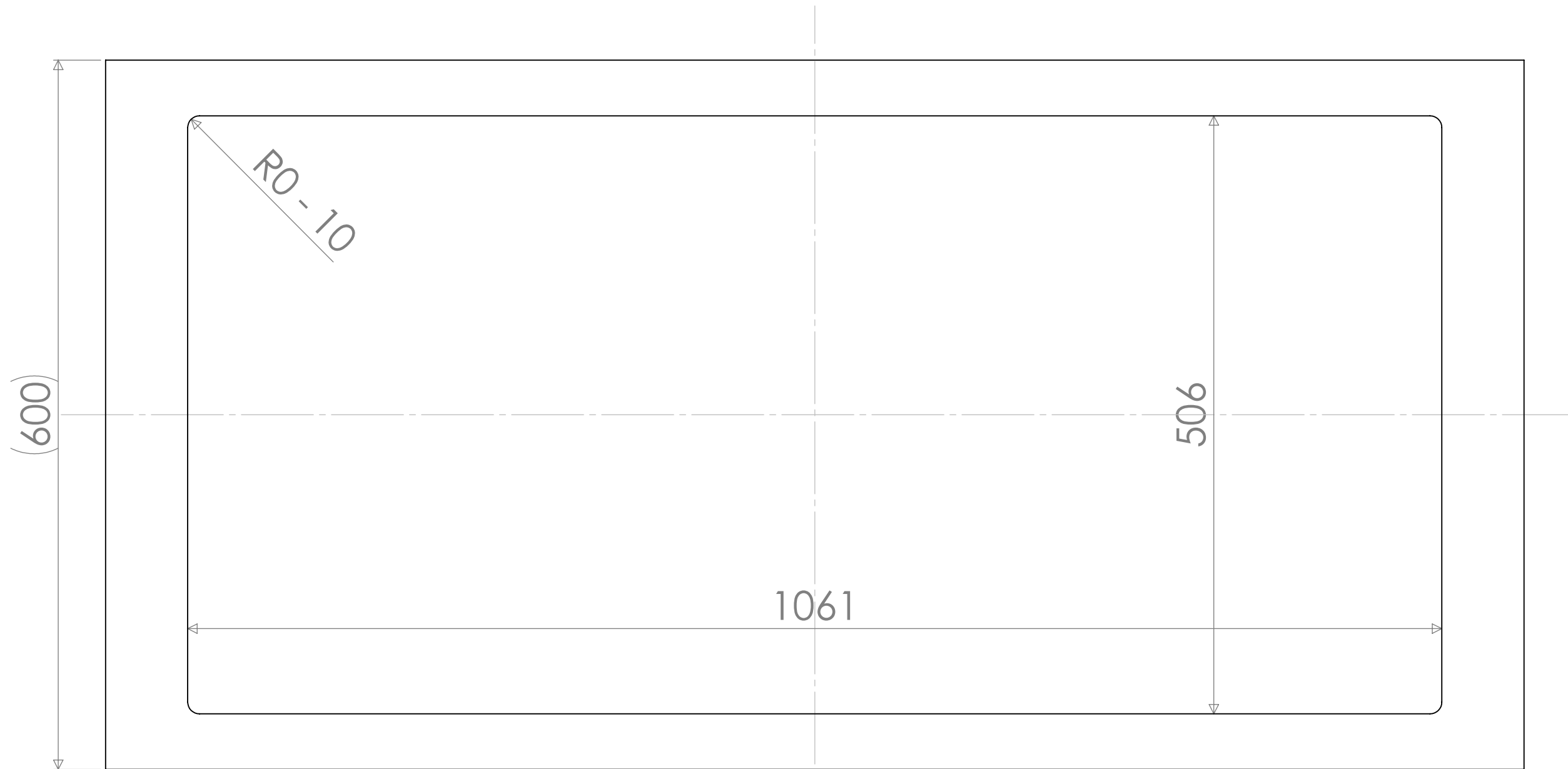
# CUT - OUT FOR BUILT ON



	Massa <b>15.10 kg</b>	Yleistoleranssi <b>ISO-2768-m</b>	Suunnittelija <b>JP</b>	Pvm <b>18.6.2007</b>
	Mittakaava <b>A3 1:4</b>	Nimike <b>EASE</b>	Tarkastaja	Pvm
 www.stala.com	Nimitys <b>MA-40-40S</b> <b>Technical Data Sheet</b>		Piirustusnumero <b>10105</b>	Sivun <b>4/6</b>
				Rev <b>M</b>

