

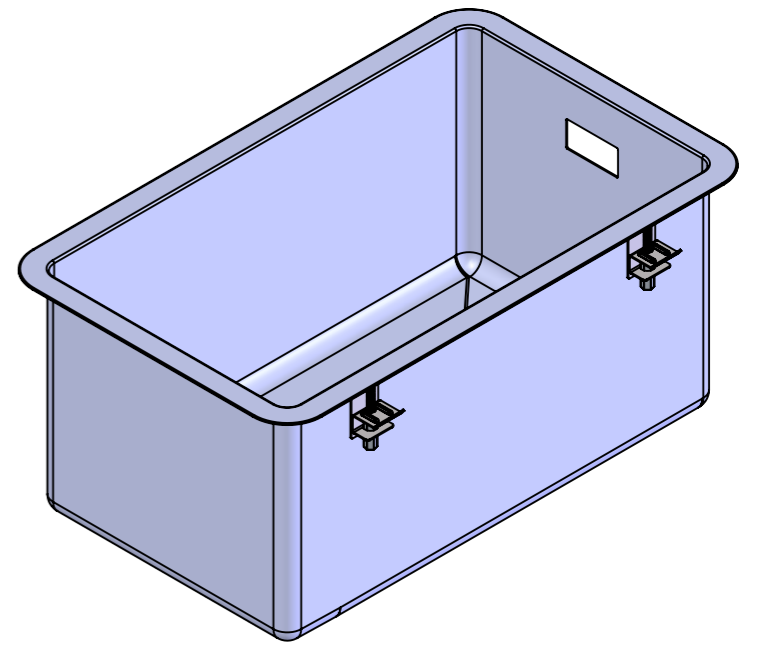

# Main dimensions

REVISION	Muutos	Pvm	AUTHOR
A		28.4.2017	jaripe+

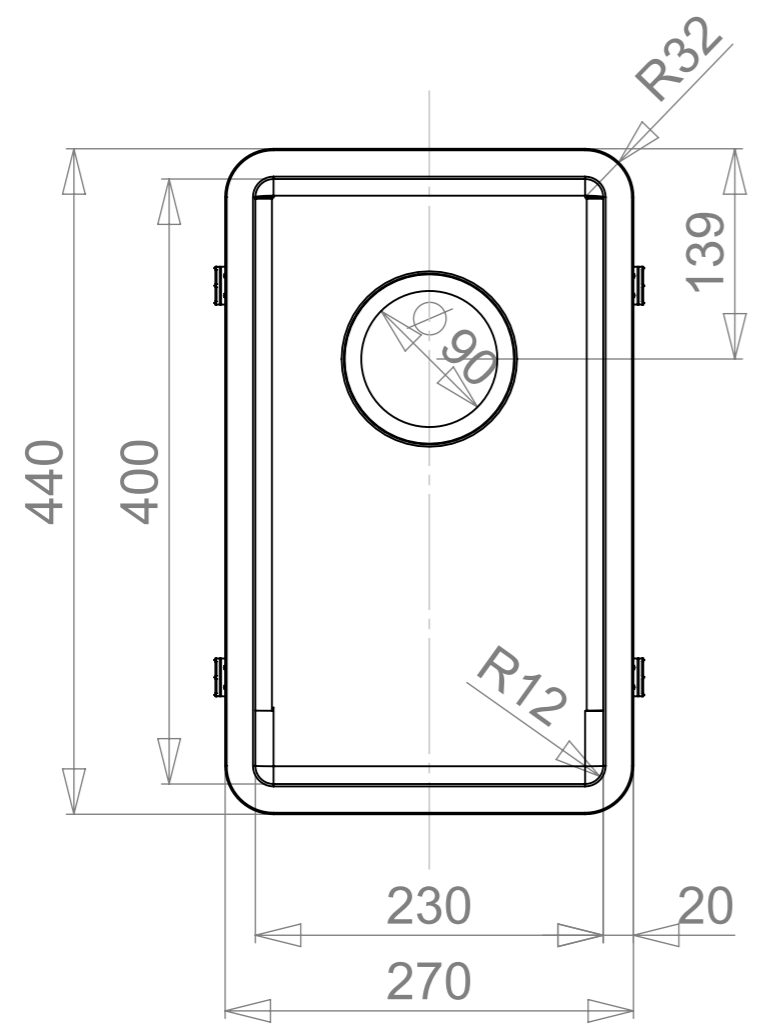
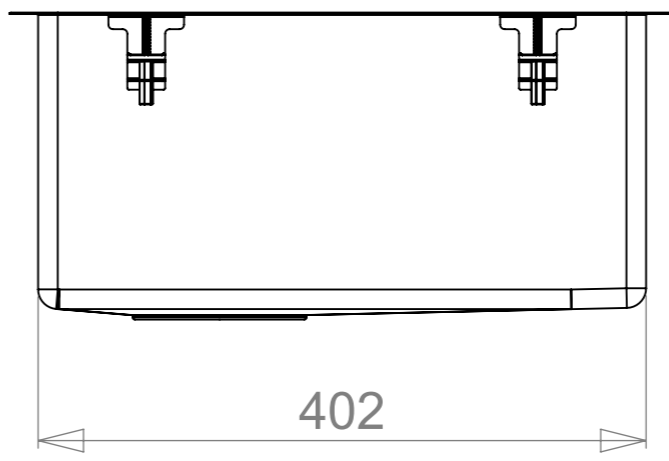
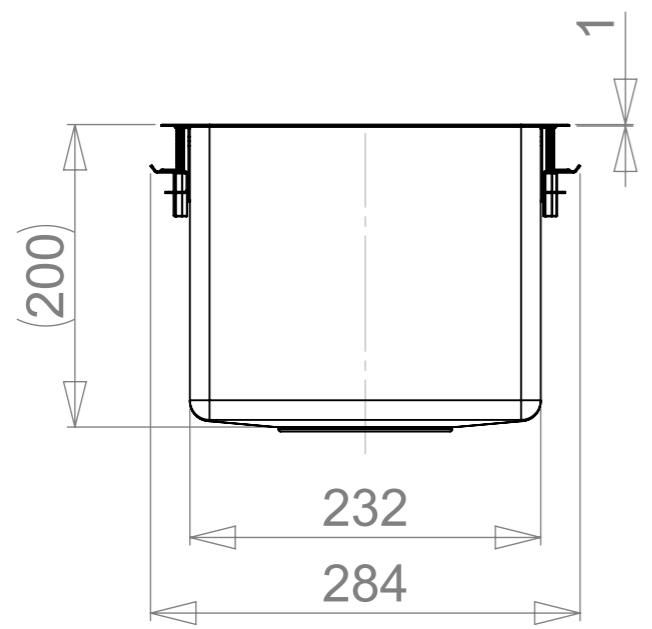

 www.stala.com	Massa kg	Yleistoleranssi	Suunnittelija JP	Pvm 24.10.2016
	Mittakaava A3 1:5	Nimike	Tarkastaja	Pvm
	Nimitys MX-30	Piirustusnumero 14489	Sivu 1/5	Rev A
Technical Data Sheet				

# Worktop assembly

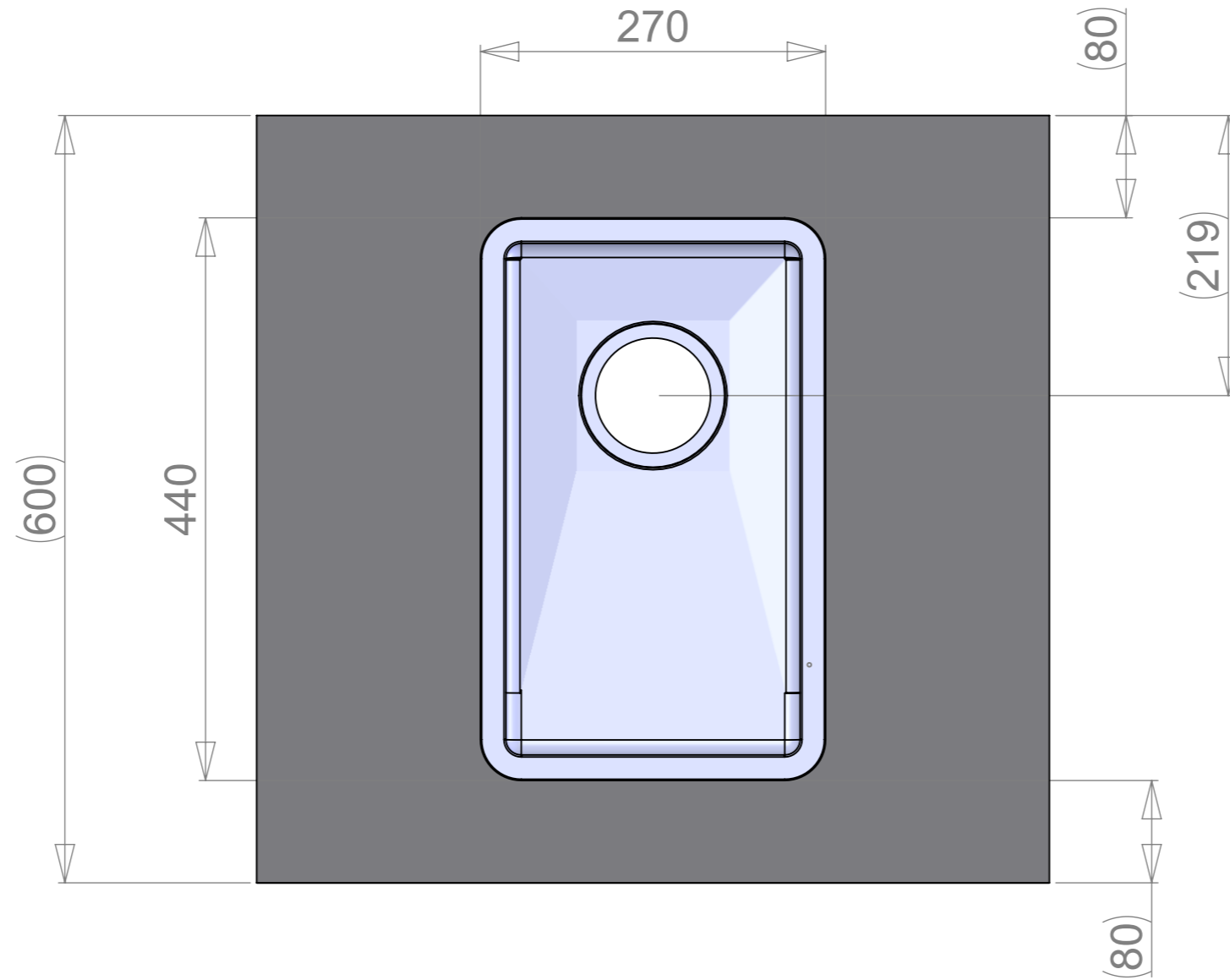

	Massa	Yleistoleranssi	Suunnittelija	Pvm
	kg		JP	24.10.2016
	Mittakaava	Nimike	Tarkastaja	Pvm
	A3	1:5		
 www.stala.com	Nimitys	Piirustusnumero	Sivu	
	MX-30	14489	2/5	
	Technical Data Sheet		Rev	A

Cut - out for built on

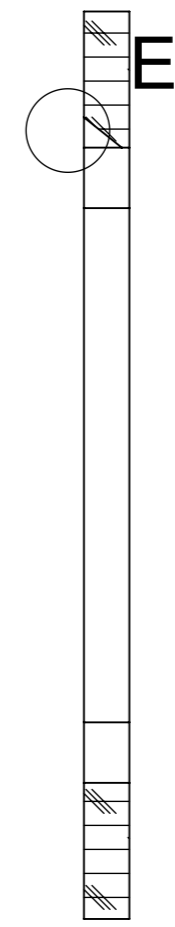
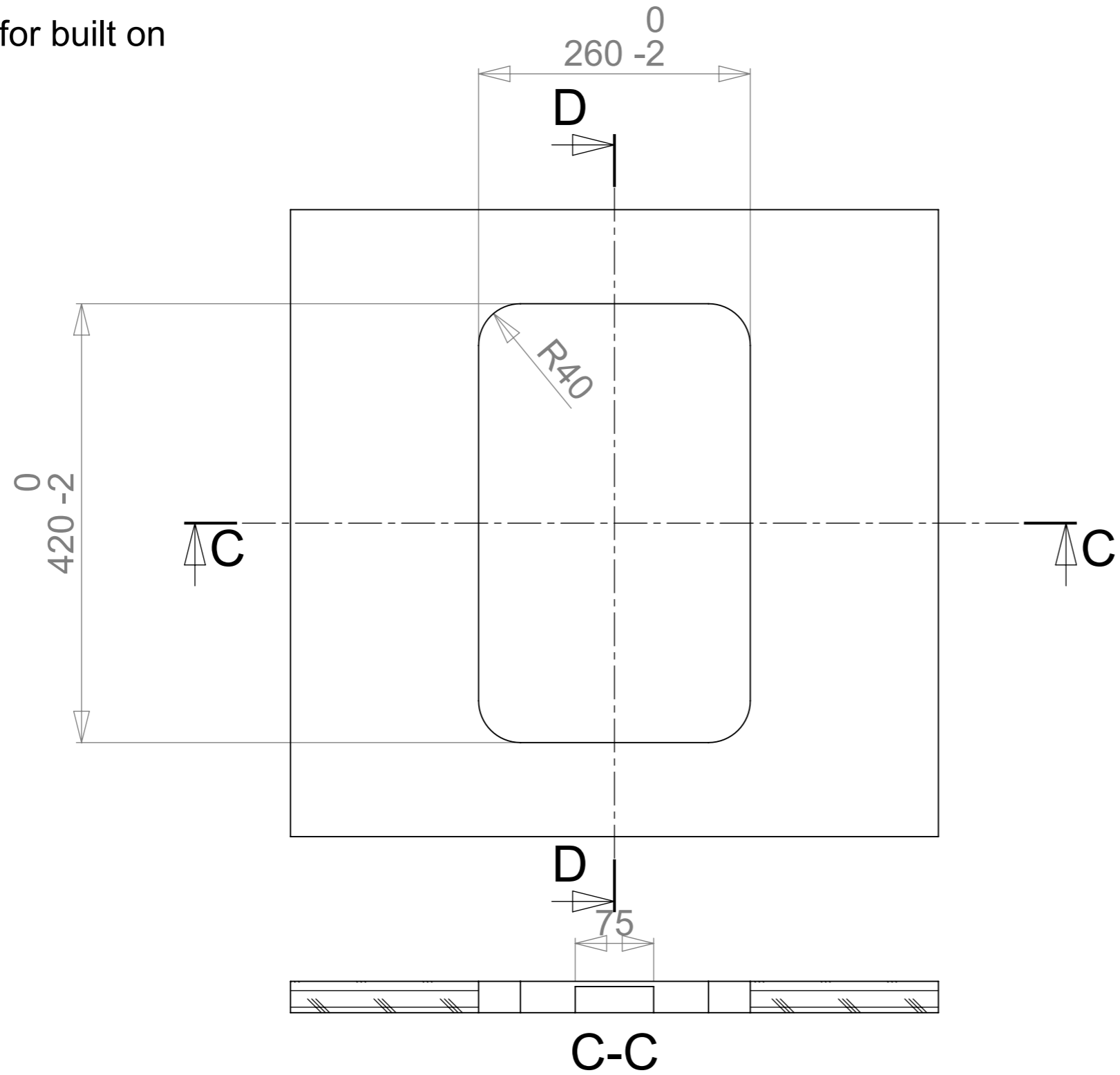

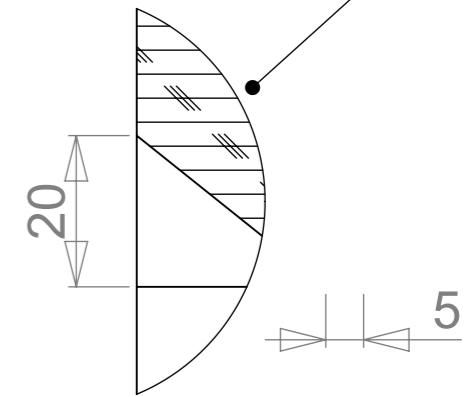

D-D

Ylivuodon väistö.  
Cut for overflow.

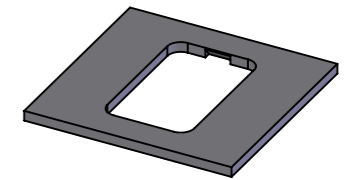

E (1 : 1)



	Massa	kg	Yleistoleranssi	Suunnittelija	Pvm
	Mittakaava	1:5	Nimike	JP	24.10.2016
 www.stala.com	Nimitys		Tarkastaja	Pvm	
	MX-30		Piirustusnumero	Sivu	3/5
	Technical Data Sheet		14489	Rev	A